

# 4 IN. BALL LAUNCHER

## Engine Mounted / PTO Driven

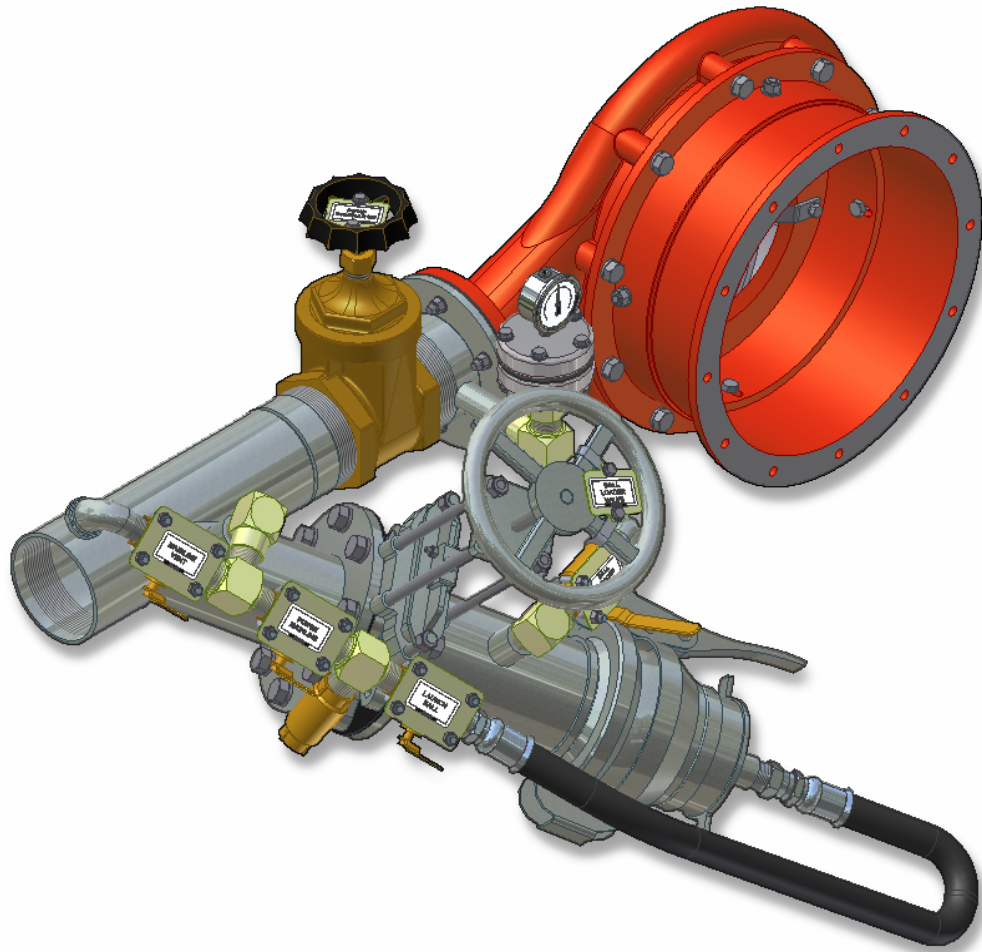

**OPERATOR'S PARTS and MAINTENANCE MANUAL**  
**2006 EDITION**

**Cadman**  
**POWER EQUIPMENT**

*Limited*

AGRICULTURAL MACHINERY & IRRIGATION EQUIPMENT

BOX 100, COURTLAND, ONT. CAN. NOJ 1E0

Phone (519) 688-2222 Fax (519) 688-2100



**BL-MAN-4EN**



**Cadman**  
**POWER EQUIPMENT**

*Limited*  
 AGRICULTURAL MACHINERY & IRRIGATION EQUIPMENT  
 BOX 100, COURTLAND, ONT. CAN. NOJ 1E0  
 Phone (519) 688-2222 Fax (519) 688-2100



**BL-MAN-4EN**

**Clean-out Ball Launcher - 4 IN.**

Creation		Revision	
date:	<b>10MAR06</b>	date:	
by:	<b>Ivon LeBlanc</b>	by:	

**Table of Contents**

Table of Contents ..... 1

Clean-out Ball Launcher System ..... 3

Safety Note ..... 3

Exercise Extreme Caution When Working With Compressed Air! ..... 4

Definitions ..... 5

Important Note ..... 5

Safety Decals ..... 6

Clean-out Ball Launcher Operation ..... 7

Parts Section ..... 15

Required Maintenance ..... 20

Useful Information ..... 22

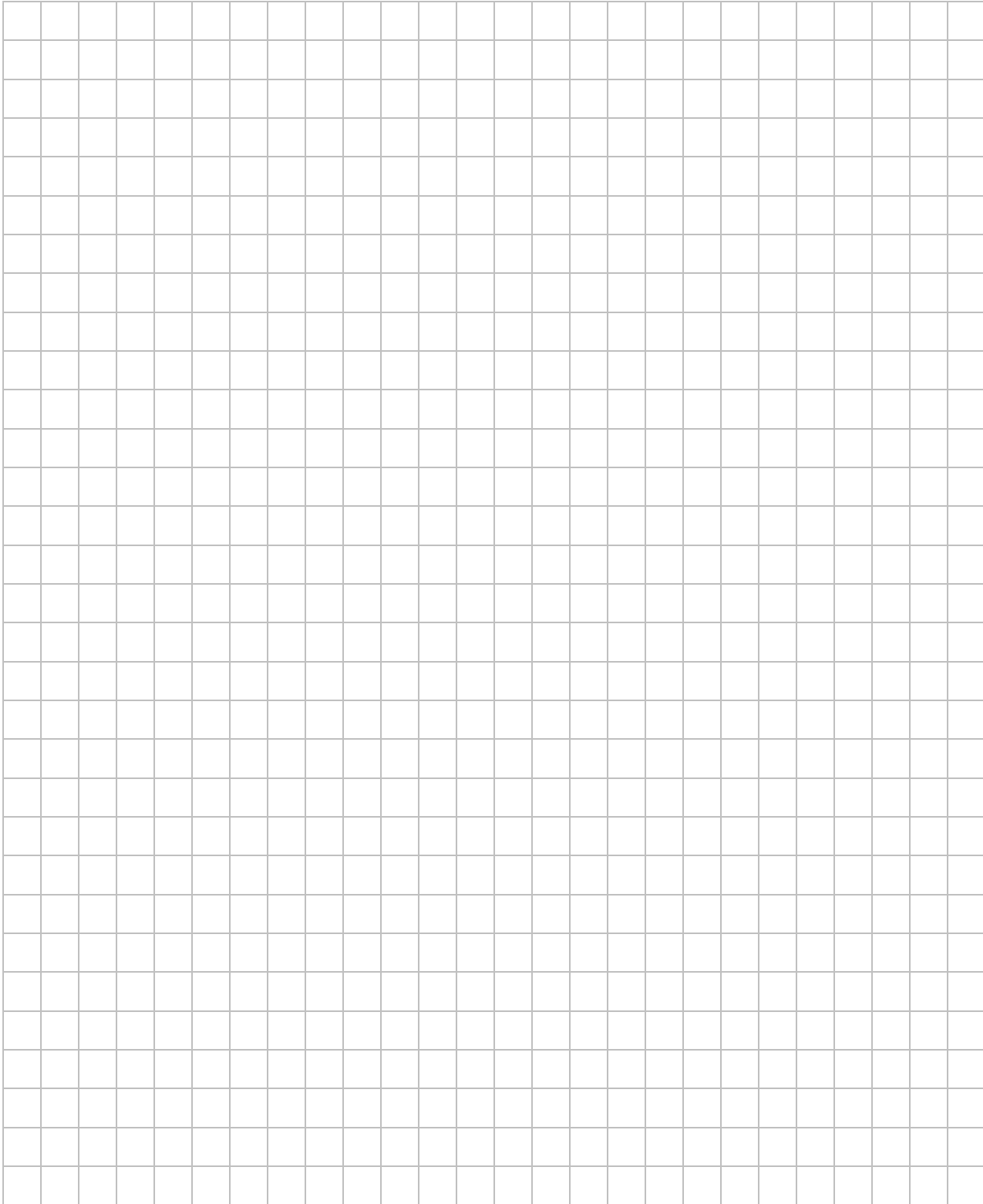

## Clean-out Ball Launcher System

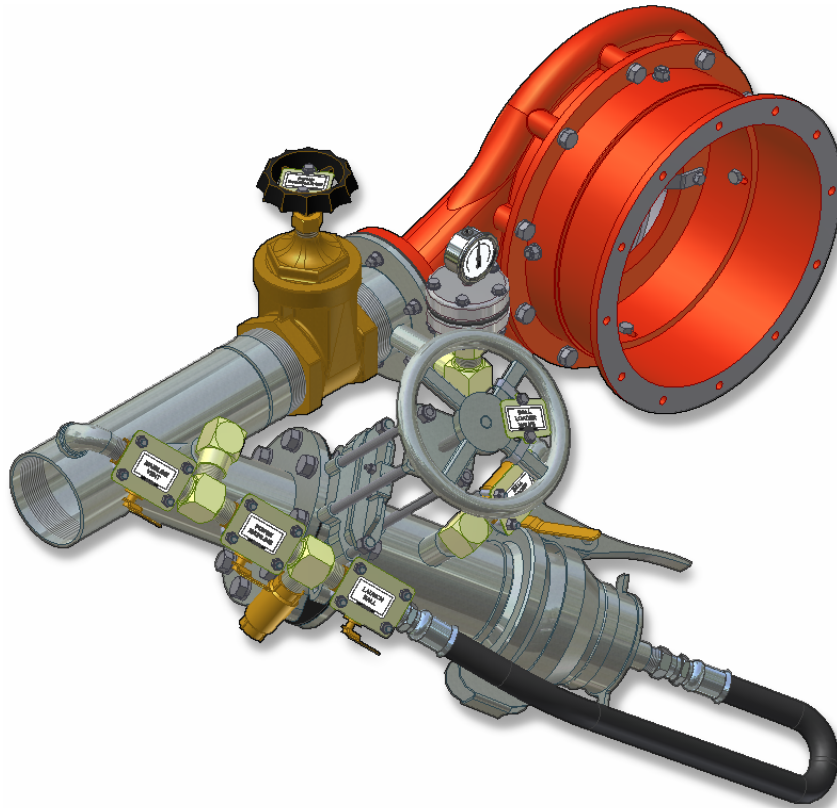

*Figure 1 – Typical 4 Inch Clean-out Ball Launcher (PTO Version shown)*

*img-00160.png*

### NOTE:

This system is **NOT** intended for use on “**CLUTCHED**” pumps. No provision has been made for a discharge check valve to prevent flow reversal from the mainline.

This system is intended to purge and clean the fluid distribution mainline by using **LOW** pressure air pushing a purge ball or foam bullet (see Figure 3). This allows for continued spreading while the supply line is being emptied, eliminating the risk of “ponding” of fluid in the field when supply line is disassembled. This in turn will ease the strain and hardship of moving the equipment by eliminating the extra weight of the fluid.

### Safety Note



This symbol, the safety-alert symbol, indicates a hazard. When you come across this safety-alert symbol in this manual, make certain you fully understand and abide by the given instructions or warnings.



## Exercise Extreme Caution When Working With Compressed Air!

Cadman recommends using a clean-out ball or bullet every time the mainline is purged with air. Using a clean-out ball or bullet minimizes the chance of air being trapped in the fluid (see *Figure 2 below*) and creating an “Air-Fluid-Air” danger.

“Air-Fluid-Air” danger occurs when a clean-out ball or bullet is not used, allowing compressed air to mix with the fluid in the mainline. If air needs to be vented (*to clear a plugged mainline etc.*) the condition illustrated in Figure 2 is likely to occur.

As air is vented at the pump, trapped higher pressure air causes the fluid to move toward the vent. As the pressure drops at the pump (vented) end, the fluid accelerates, pushed along by the trapped air. When the air ahead of the moving fluid is completely expelled, the fast moving fluid will impact the fittings and pump equipment with GREAT force (*often measured in TONS!*). This impact can be very violent, creating conditions which can damage or explode the pumping equipment, putting the operator and spectators in danger of serious injury or death.

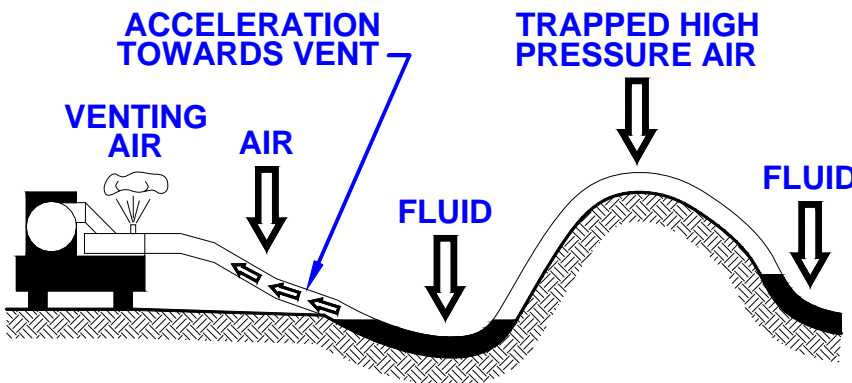

Figure 2 – Air-Fluid-Air Danger

img-00025.wmf

### OPERATOR NOTE

This graphic is exaggerated.

Small inclines to the landscape can cause the same effect. The ball launcher should be set-up on the high side of the field where possible.

If this is not possible take extra care when using the clean-out system.

**SAFETY FIRST!**



Contained pressure systems will seek equilibrium (balance). When an imbalance exists, movement will occur to restore balance.

## Definitions

### Clean-out Ball:

A device used to purge or clean the mainline of a fluid distribution system. This device can take the form of a ball or bullet. See Figure 3.

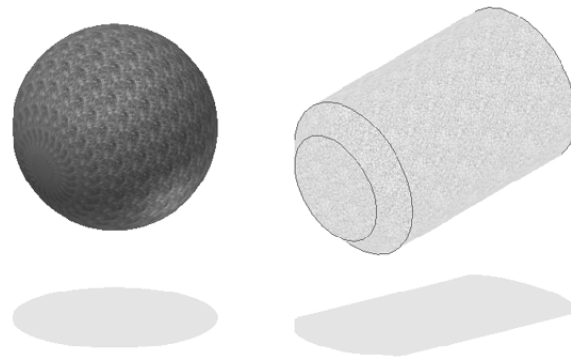

*Figure 3 – Clean-out Ball and Bullet*

*img-00016.gif*

## Important Note

Things to keep in mind while using the Clean-out Ball Launcher System are:

- The hose is a high volume “Receiver Tank” containing a large amount of fluid. Be sure to allow enough spreading area to properly distribute the hose contents.

Ø 6” hose contains approximately 1 ½ US Gallons per foot

Ø 8” hose contains approximately 2 ⅔ US Gallons per foot

	660	1320	1980	2640	3300	3960	4620	5280	5940	6600	Feet
Ø 6”	969	1939	2908	3877	4847	5816	6785	7755	8724	9693	US Gal
Ø 8”	1723	3447	5170	6893	8616	10340	12063	13786	15509	17233	US Gal

- Hose couplings should be maintained and in good working order. Check for broken or damaged couplings and replace where necessary.
- Air pressure must be kept to the lowest level required to complete the clean-out process. Excess pressure will result in equipment damage and may result in personal injury or death.

## Safety Decals

The safety decals on this machine are intended to warn the operator of potential hazards. It is important that these decals are properly maintained.

- keep all safety decals legible (remove dirt or debris)
- replace any damaged or illegible decals
- replace any missing decals
- if applicable, include the current safety decal specified by **Cadman Power Equipment Limited** on any components installed during repair

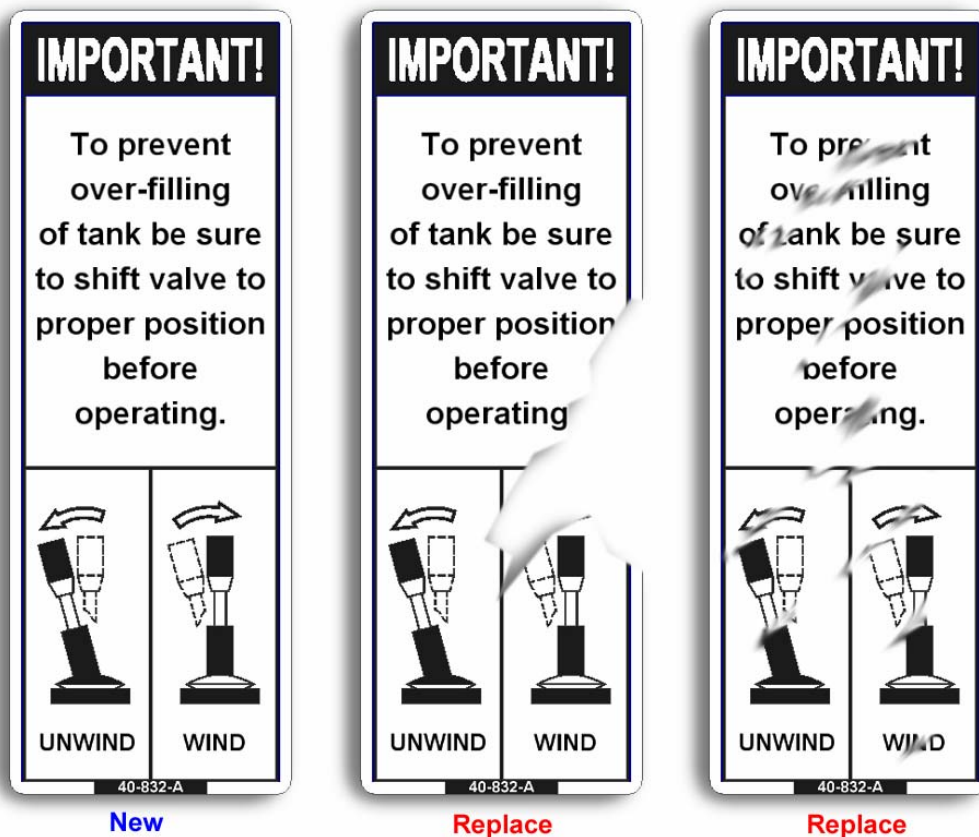

Figure 4 - Replace Decals

img-00131.png

To obtain the required replacement safety decals contact **Cadman Power Equipment Limited**. Re-install all decals in the proper location on the machine. For part numbers and locations please refer to the Assembly drawings of this manual.



## Clean-out Ball Launcher Operation

If the clean-out ball was inserted during the initial set-up (**preferred**), complete the following instructions skipping steps 3 through 5.

In the event the clean-out ball was not loaded into the launcher during initial set-up on site, complete the following instructions to purge the supply line.

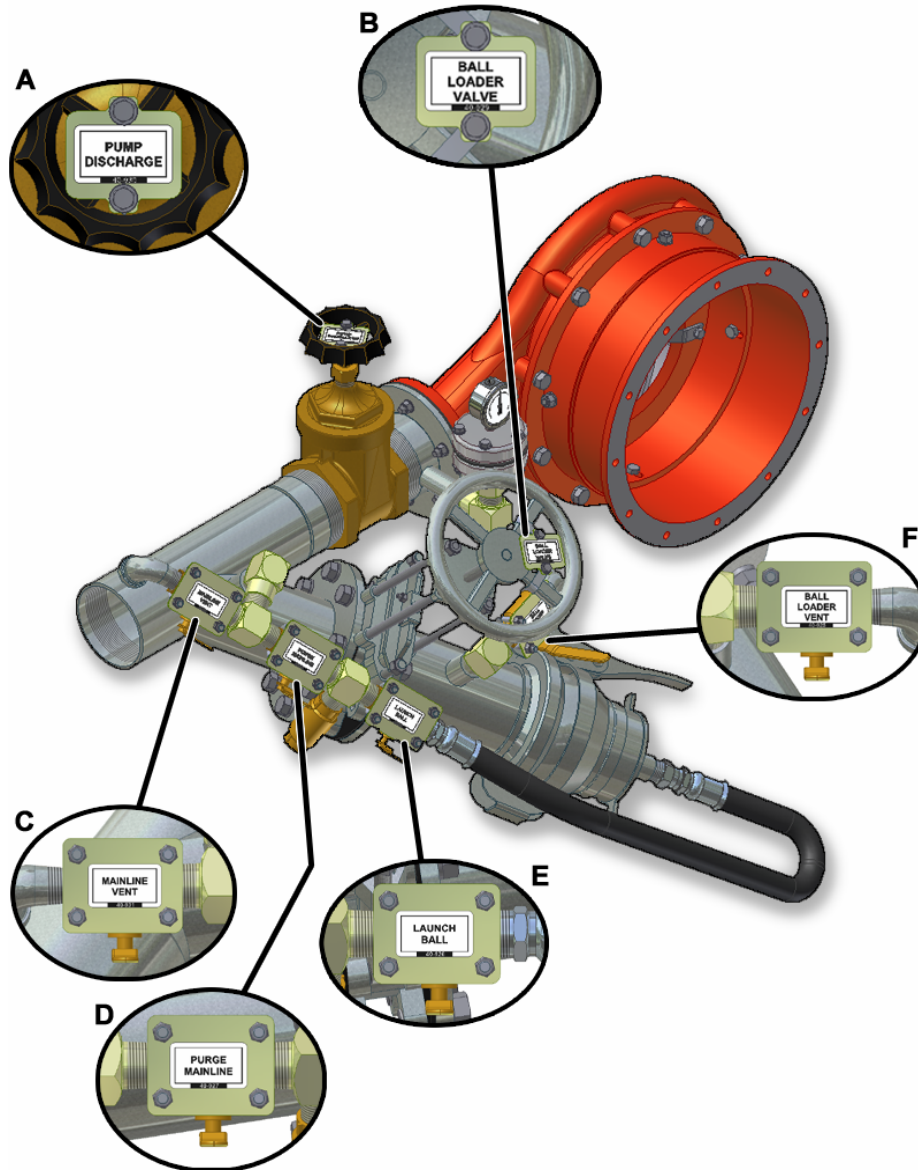

Figure 5 – 4 Inch Clean-out Ball Launcher Valve Layout

img-00161.png

- |                      |                     |
|----------------------|---------------------|
| A) Pump Discharge    | D) Purge Mainline   |
| B) Ball Loader Valve | E) Launch Ball      |
| C) Mainline Vent     | F) Ball Loader Vent |

**Step 1**

Stop pumping fluid to begin the clean-out procedure.

**Step 2**

Close the Pump Discharge Valve (see Figure 5 item A).

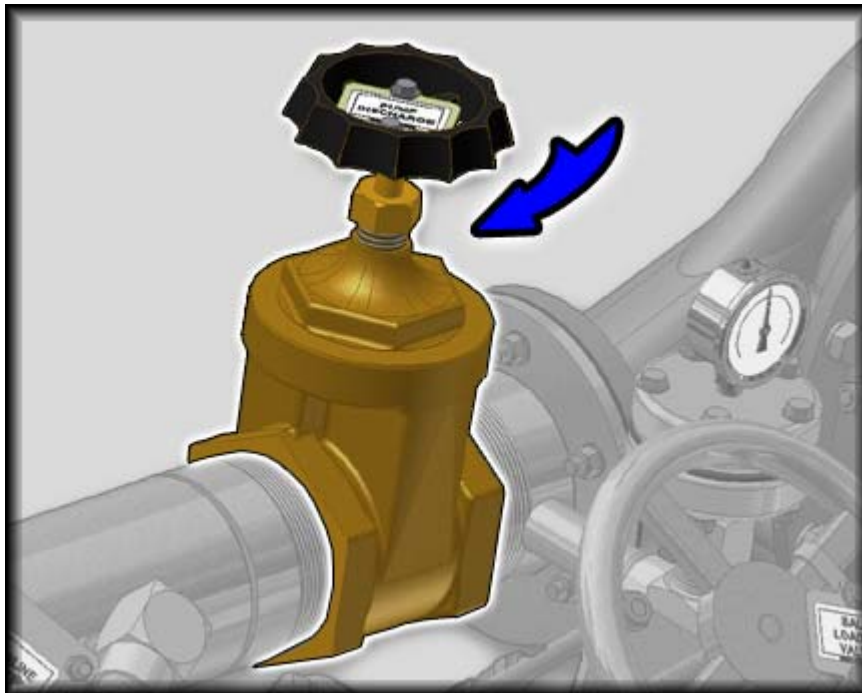

*Figure 6 – Pump Discharge Valve – Close Gate Valve*

*img-00162.png*



**Failure to properly close valve will result in pump damage and can cause serious injury or death. Pump can freely rotate under air pressure acting like a turbine. This will result in damage to the pump and may cause the pump to break apart, putting the operator at risk of serious injury or death.**

**Step 3**

Verify the Ball Loader Valve (see Figure 5 item B) is in the closed position.

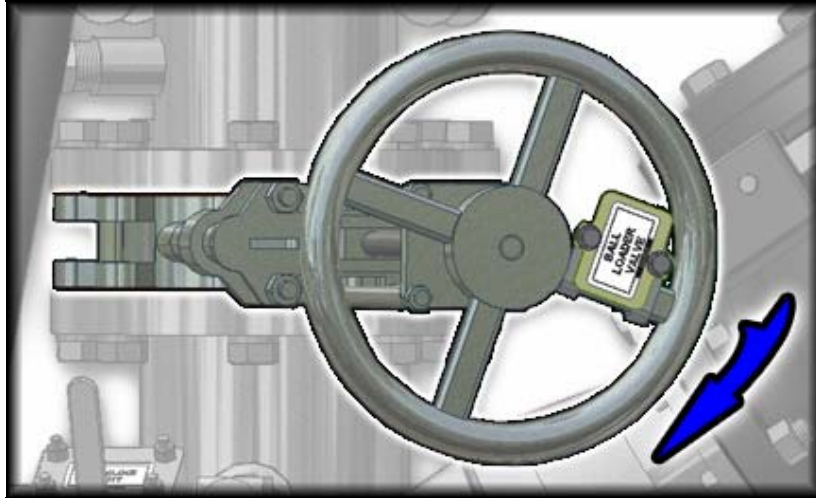
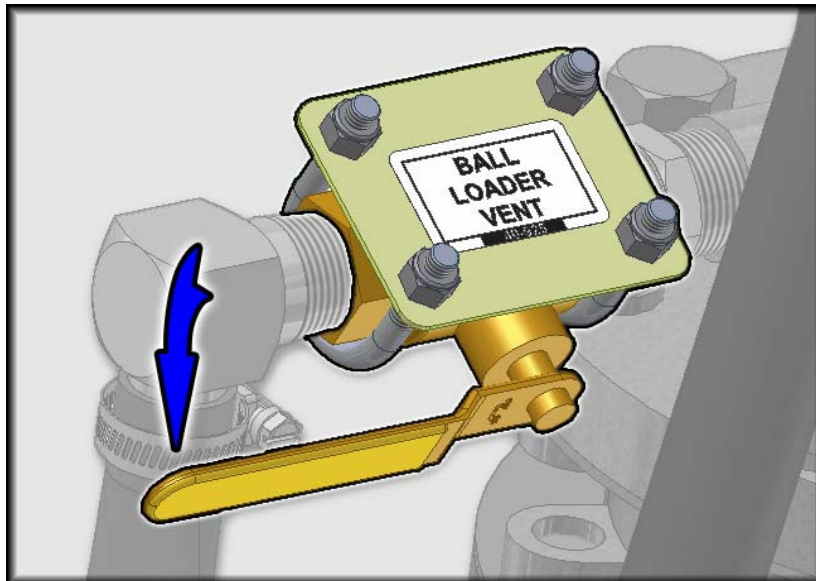

*Figure 7 – Ball Loader Valve – Close Knife Gate Valve*

*img-00148.png*

**Step 4**

Open ball valve labeled “Ball Loader Vent” (see Figure 5 item F) **BEFORE** attempting to load clean-out ball.

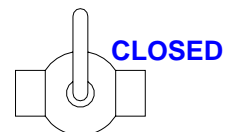
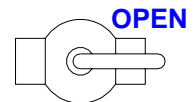

*Figure 8 – Ball Loader Vent – Open Ball Valve*

*img-00149.wmf*

**OPERATOR NOTE**

As a general rule ball valves are **OPEN** when the handle is parallel to flow and **CLOSED** when perpendicular to flow.



*img-00017.wmf*

**Step 5**

Remove Clean-out Ball Loader cap, insert the clean-out ball and recap the loader. Close ball valve labeled "Ball Loader Vent" (see Figure 5 item F).

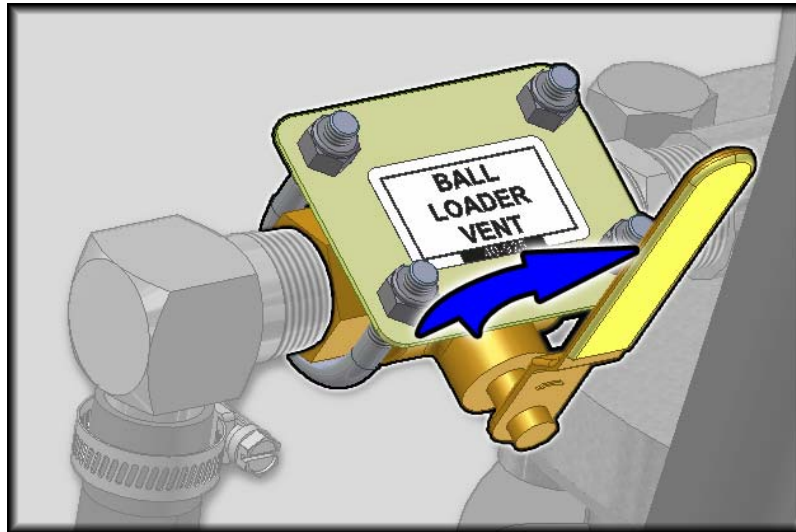
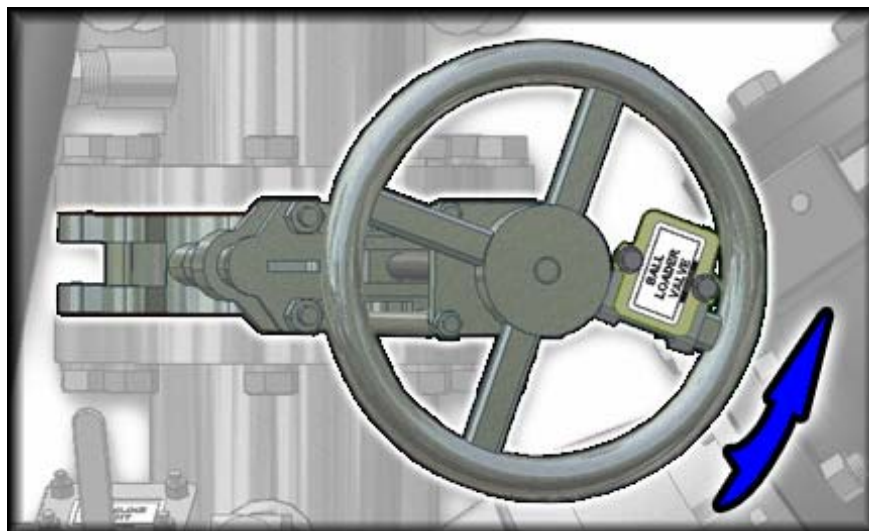

*Figure 9 – Ball Loader Vent – Close Ball Valve*

*img-00150.png*

**Step 6**

Open Ball Loader Valve completely (see Figure 5 item B).



*Figure 10 – Ball Loader Valve – Open Knife Gate Valve*

*img-00151.png*

### Step 7

Open ball valve labeled “Launch Ball” (see Figure 5 item E).

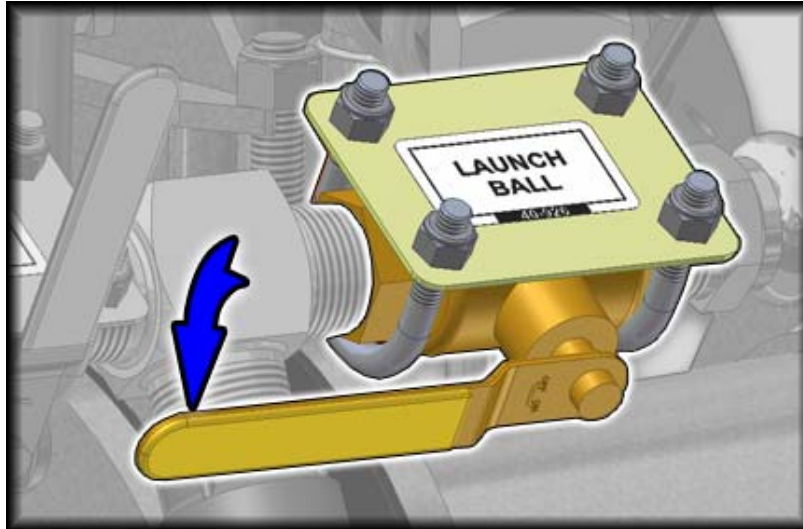

Figure 11 – Launch Ball – Open Ball Valve

img-00163.png

### Step 8

Turn on compressor.

### Step 9

Verify that ball has entered the mainline. Tap the hose and it should have a hollow sound. Do the following in the sequence stated; open ball valve labeled “Purge Mainline” (see Figure 5 item D) to divert air to mainline tube, **CLOSE** ball valve labeled “Launch Ball” (see Figure 5 item E) to launcher. Completely close the Ball Loader Valve **IMMEDIATELY!** (see Figure 5 item B)



**Failure to properly close Ball Loader Valve may cause equipment damage with the potential for serious injury or death. In the event of flow reversal, the Ball Loader Valve helps protect the operator from a burst hazard.**

### Step 10

Continue adding air until Clean-out Ball clears the hose. Once the ball is past the halfway point in the mainline, cycle compressor on and off to add air intermittently until the ball exits the hose. This ensures minimal air pressure remains when the line clears.

### Step 11

Turn off compressor.

### Step 12

Close ball valve labeled “Purge Mainline” (see Figure 5 item E) at manifold.

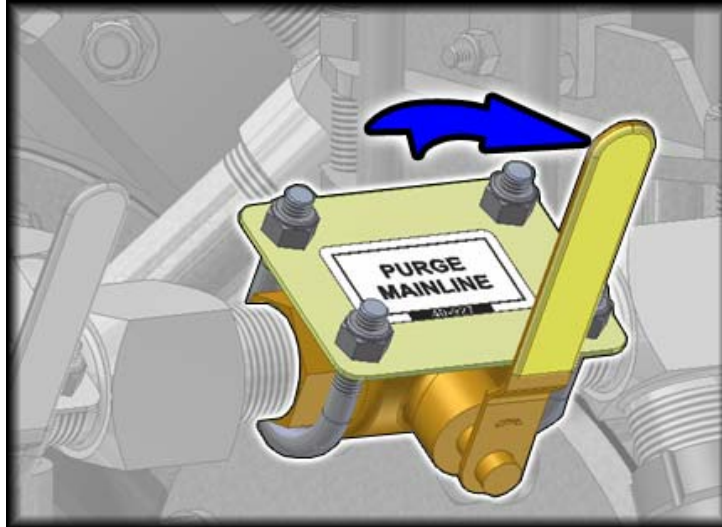
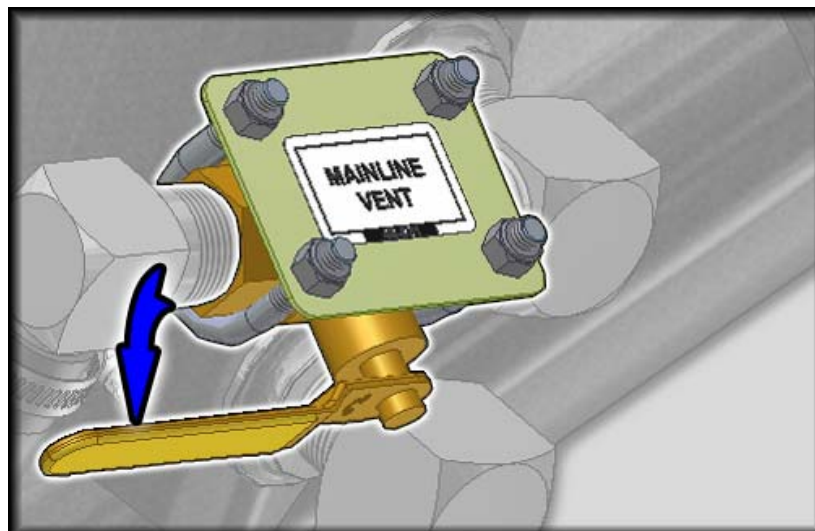

*Figure 12 – Purge Mainline – Close Ball Valve*

*img-00153.png*

### Step 13

Open ball valve labeled “Mainline Vent” (see Figure 5 item B) to relieve remaining air pressure completely **before** uncoupling the mainline hose.



*Figure 13 – Mainline Vent – Open Ball Valve*

*img-00154.png*



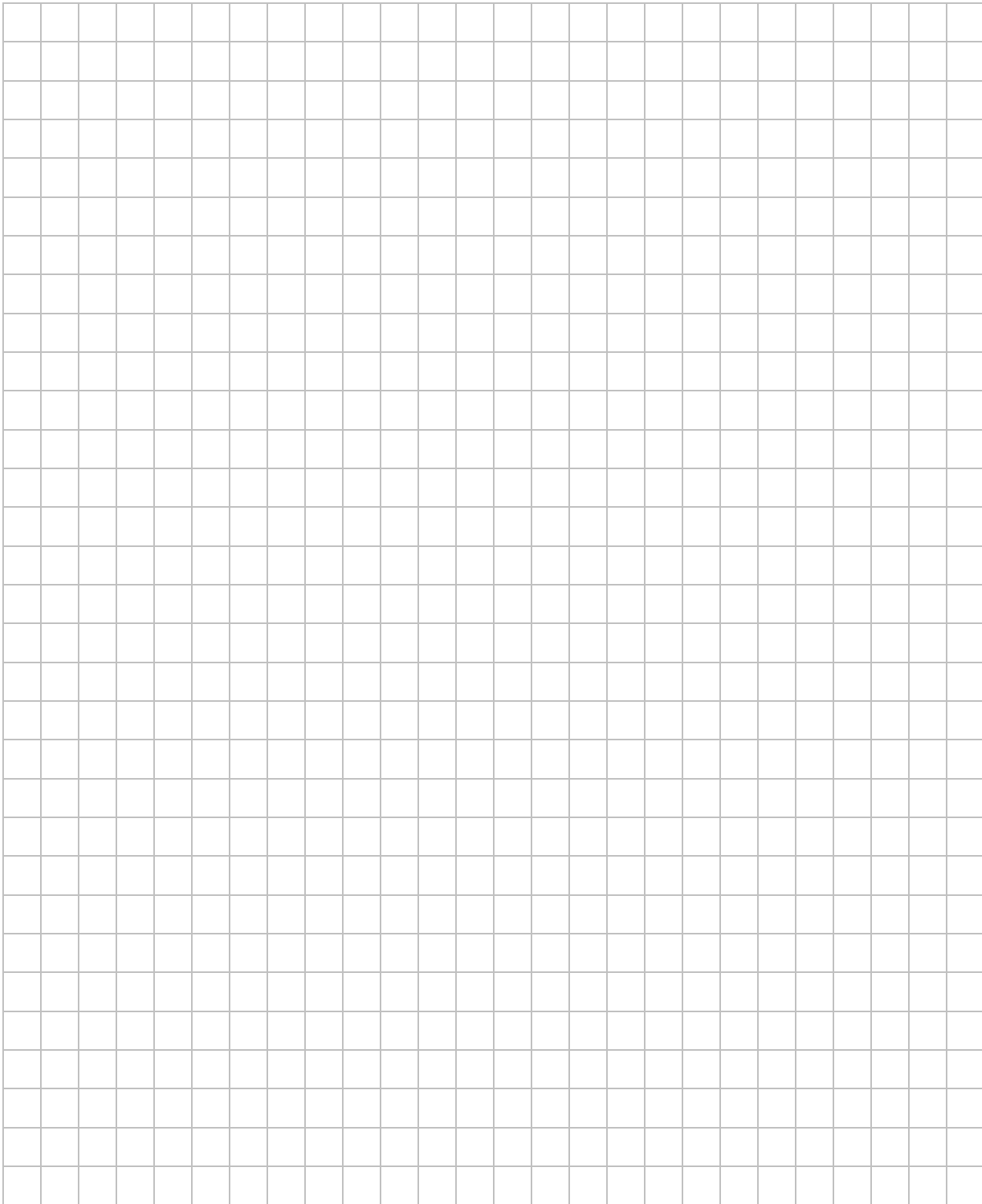



# Parts Section

4 IN. BALL LAUNCHER KIT – ENGINE MOUNT .....	16
4 IN. BALL LAUNCHER KIT – PTO MOUNT .....	18

**4 IN. BALL LAUNCHER KIT – ENGINE MOUNT**

**BL-ENG-K4**

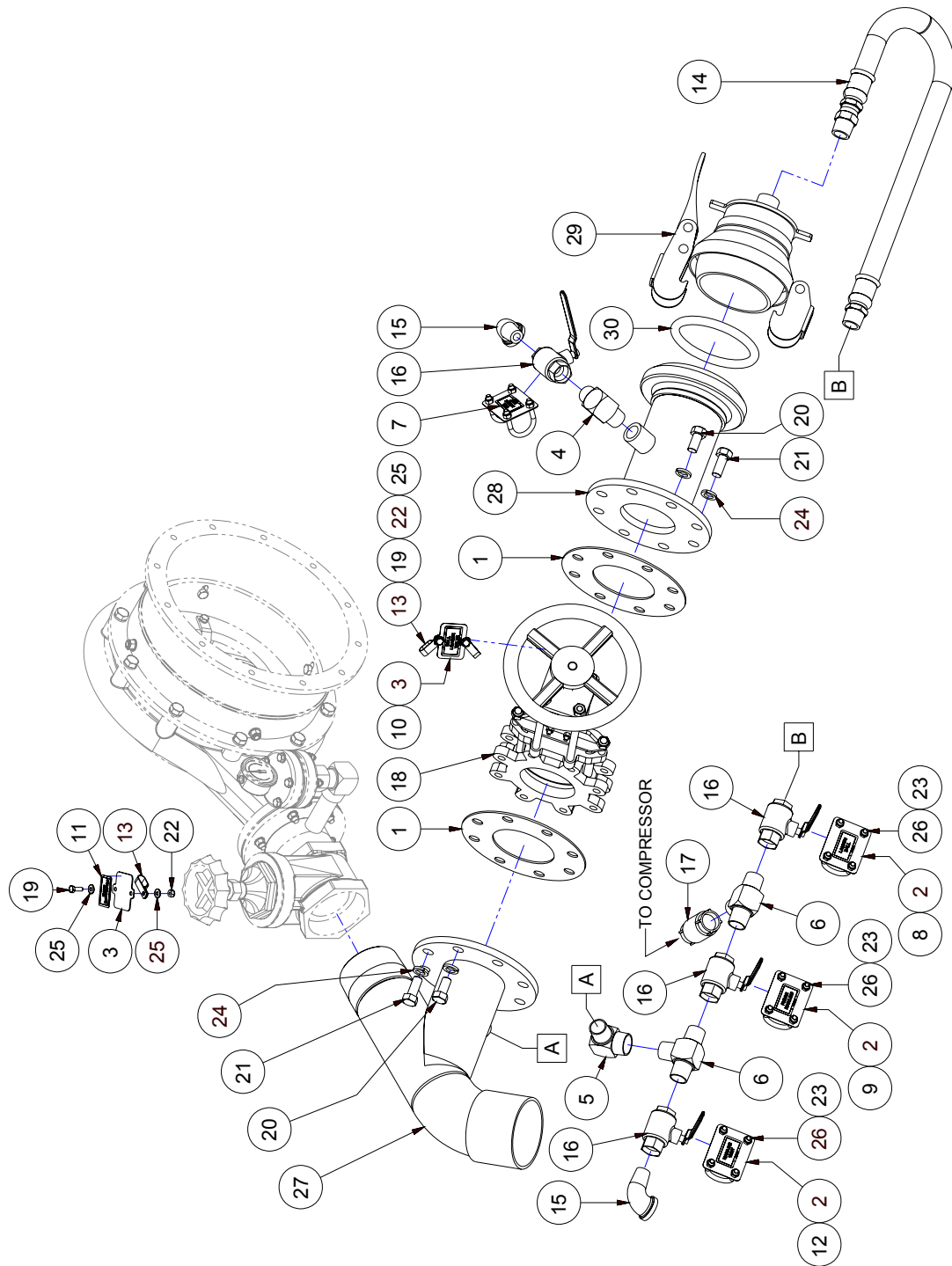



**4 IN. BALL LAUNCHER KIT – PTO MOUNT**

**BL-PTO-K4**

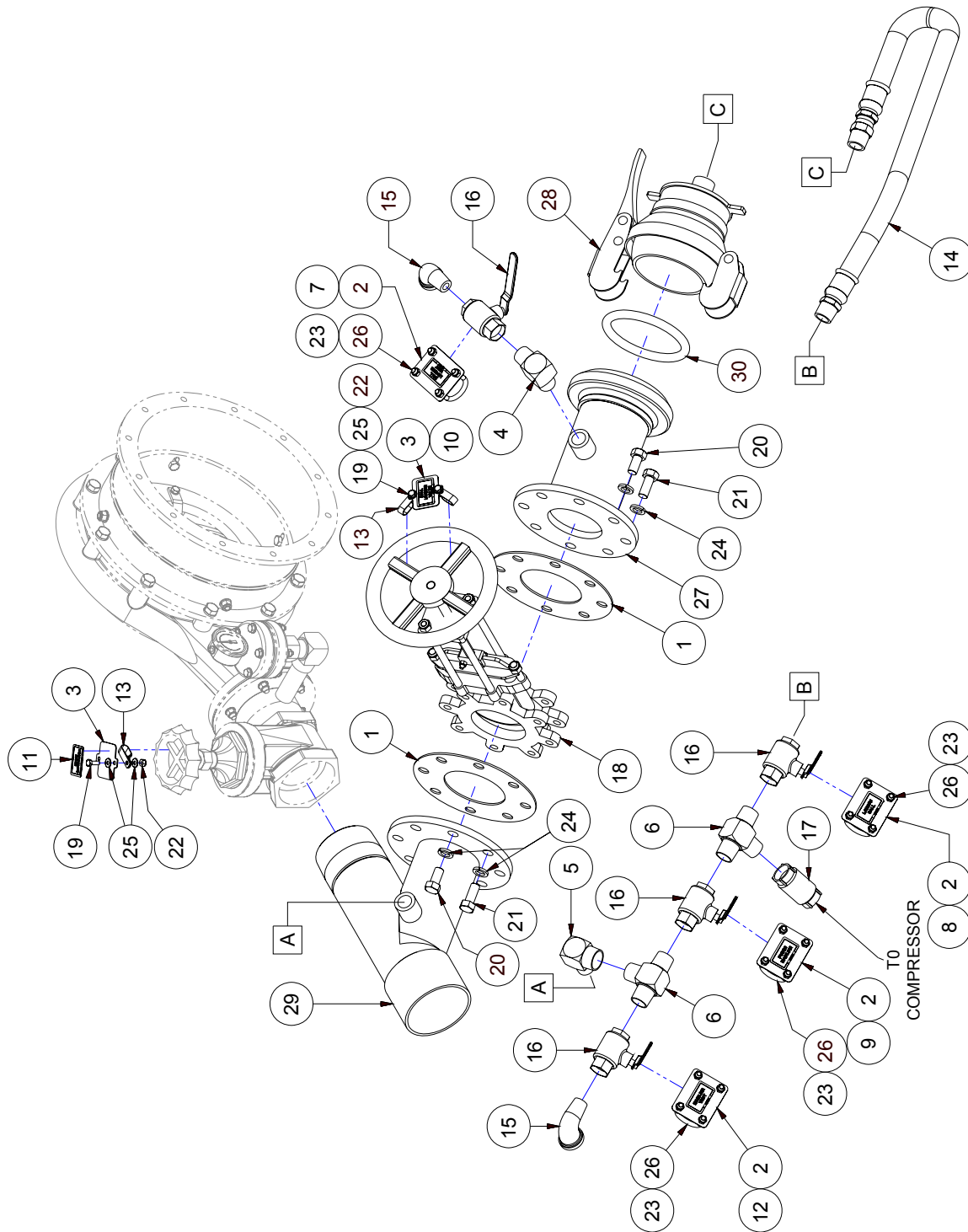



## Required Maintenance

Prevention of mechanical failure is the goal of any good maintenance schedule. The secret to preventing unwanted down time is to adhere to a maintenance schedule suited to the way you use the equipment. Your maintenance schedule should include the following minimum requirements:



**Maintenance must be done ONLY when the machine is shut down and is in a non-loaded condition. This means that no fluid is being pumped through the system. All system pressure must be discharged prior to any maintenance operation is performed.**

### Each Use

Maintenance Item	Figure	Procedure
Visually inspect equipment	N / A	Walk around the unit and inspect for loose, missing or damaged items. Check the condition of the ball loader plug, hoses and valves. Replace missing or damaged items and tighten loosened items.
Check knife gate valve for leaks	Figure 14	Leakage may occur around the valve gland. Tighten all gland nuts by a quarter turn to stop the leakage. Repeat until leakage has stopped.  <b>DO NOT over tighten these gland nuts. By over tightening you will damage the valve seal.</b>
Check for leaks	N / A	Tighten all joints where leaks appear. Replace any damaged gaskets where required.

Table 1 - Required Maintenance - Each Use

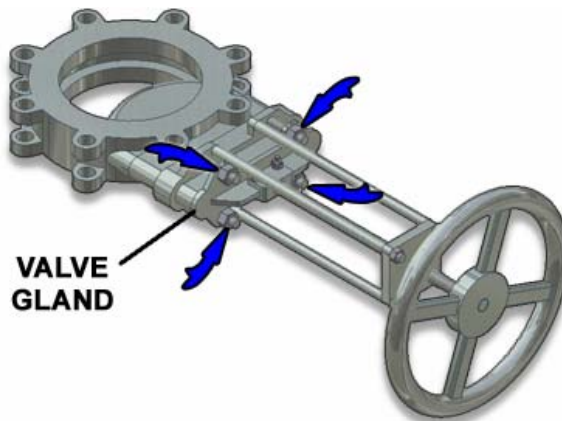

Figure 14 - Knife Gate Valve

img-00158.png

**Before Storing**



**You MUST properly empty and flush your Clean-out Ball Launching System before storing the unit for more than one day. Failure to properly clean out the system could result in the unit being plugged with sediment.**

Maintenance Item	Figure	Procedure
Clean the system	N / A	Flush with water prior to storage of the unit. This will remove sediment and prevent clogging the unit. Wash down the exterior to remove any dirt and debris.
Drain unit	Figure 15	Before storing the system must be drained. Open all valves to allow the water to drain from the unit.
Lubricate Knife Gate Valve	N / A	Lubricate the center screw with acceptable grease. (see "Lubricants")

Table 2 – Required Maintenance - Before Storing

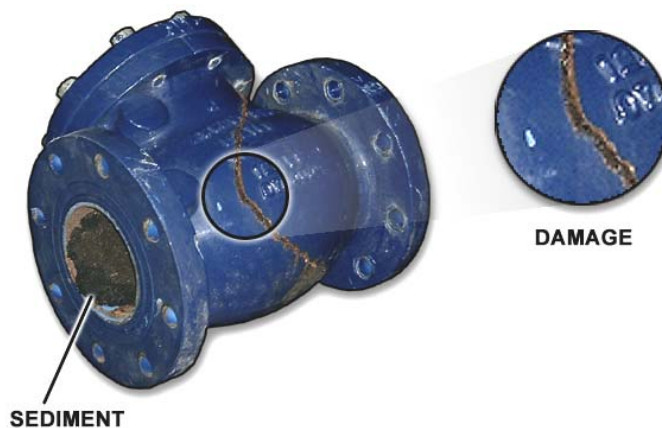

Figure 15 - Valve Damage (result of improper storage)

img-00159.png

**ATTENTION**

Failure to remove all liquid from the clean-out ball launcher will result in extensive damage to your equipment. Before storing the unit, open all the valves.

**NOTE:**

Proper storage of the **Cadman Clean-out Ball Launcher** will greatly prolong the operational life of the unit.

**Lubricants**

**Grease:** Any good grade multi-purpose, waterproof grease is compatible with the greasing requirements of your **Cadman Clean-out Ball Launcher**.

**Useful Information**

**LENGTH**

1 FOOT = 12	Inches	1 METER = 39.37	Inches
1 ROD = 0.3048	Meter	1 MILE = 5280	Feet

**AREA**

1 SQUARE FOOT = 144	Square Inches
= 0.0929	Square Meters
1 SQUARE YARD = 1296	Square Inches
= 0.8361	Square Meters
1 SQUARE METER = 1549.4	Square Inches
= 10.764	Square Feet
1 ACRE = 43560	Square Feet
= 4047	Square Meters
= 0.4047	Hectare
1 HECTARE = 107642.62	Square Feet
= 10000	Square Meters
= 2.47105	Acres
1 SQUARE MILE = 640	Acres
= 259	Hectares

**VOLUME**

1 GALLON ( US ) = 0.8327	Imperial Gallons
= 231	Cubic Inches
= 0.1337	Cubic Feet
= 8.345	Pounds
1 CUBIC FOOT = 1728	Cubic Inches
= 7.48	Gallons ( US )
= 62.4	Pounds
= 28.32	Liters
1 ACRE INCH = 27154	Gallons ( US )
= 254	Cubic Meters / Hectare

**AREA OF A CIRCLE** = Diameter x Diameter x 0.7854

**CYLINDER VOLUME** (US GAL.) = Diameter (ft.) x Diameter (ft.) x Length (ft.) x 5.8748